

Replacement Front End for FT221/225 Early Versions

a product produced by Mutek (circa 1995)

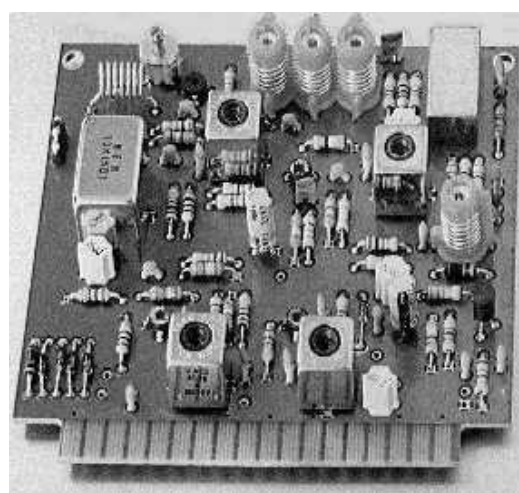
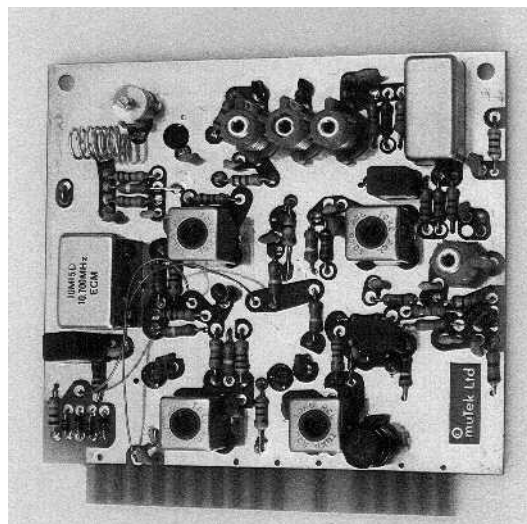

Manual compiled by Clive Smith, GM4FZH for general circulation

Table of Contents

Compilers Note.....	3
Specification.....	4
Kit List.....	4
Tools Required.....	4
History of the PCB.....	4
Introduction.....	5
Circuit Description.....	5
Figure 1: FT221/225GT Front End Block Diagram.....	6
Installation Notes.....	6
Detailed Installation.....	7
Table 1: Edge Connector Pin Allocations.....	8
Additional Notes.....	8
Figure 2: Minimum Noise Figure Modification.....	8
Data for FT221/225GT.....	9
Figure 3: FT221/225GT Circuit Diagram.....	9
Figure 4: FT221/225GT Component Layout.....	9
Table 2: FT221/225GT Component Listing.....	10
Data for RPBC144ub.....	11
Figure 5: RPBC144ub Circuit Diagram.....	11
Figure 6: RPBC144ub Component Layout.....	11
Table 3: RPBC144ub Component Listing.....	12
Copy of Change Note: #003.....	13

Compilers Note

This manual has been put together and designated Edition 1. The information has been obtained from various sources, including past owners and the Internet; **I cannot vouch for the accuracy of this information.** It is not intended to produce an updated version of this manual, if additional information becomes available it maybe provided as an addendum.

The products produced by Mutek were of high quality and many are still in service. However, please remember that this product came on to the market some 20-30 years ago and must now be regarded as obsolete.

The units described herein have been supplied in different versions which may mean some changes to component values and types. Two different versions of the early boards were identified - the FT221/225GT board and the RPBC144ub version. The differing circuit diagrams, layouts and component values are dealt with separately in this document.

This manual has no copyright but I would be grateful that if it is used the source is acknowledged. Please let me know if you have further details that would help with this or any other Mutek product.

****** PLEASE NOTE: ******

The information contained herein is provided in good faith and I will not be responsible for any outcomes arising from the use of it. I have put it together for use by the amateur radio fraternity.

The list of other manuals can be found on my website www.gm4fzh.co.uk (as they become available) where there are also details of how to contact me. I have no association with the firm Mutek and this manual has been produced at my own expense and without any payment.

Clive Smith, GM4FZH, Spring 2020

The filename of this document is *earlyfrontendFT221_5.pdf*.

Specification

Non found

Kit List

The following items are required:-

Relevant Mutek board	1 off
Connecting wire	1 off by 200mm
Connecting wire	1 off by 160mm

Tools Required

Soldering iron
 Small long nose pliers
 Side cutters
 Cross blade screwdriver
 Solder sucker
 Multi-core solder
 Multi-meter

History of the PCB

After some research, the history of this pcb (in bold) appears to be as follows, EOE.

PCB Type	Notes	Approx. date of issue
FT221/225GT pa.000.055 issue ???	Very early pcbs. Standard components, hand layout.	1979-1985
FT221/225GT pa.000.055 iss 3.12/85	Standard components, hand layout.	Circa 1985
RPCB144ub Issue 1	Standard components, using CAD layout. Re-labelling of component numbers	Circa 1989
RPCB144ub Issue 1A	See Change Note #003 at end of this document.	1991
*RPCB144 Iss 2b	Uses SMD and CAD layout.	1991 onwards

* Denotes not covered by this manual.

Introduction

Our front-end board has been designed to bring the receiver performance of the FT221 and FT225 series transceivers up to a very high standard. The design has evolved from work done by Ian White, now GM3SEK, and has been used extensively for advanced experimental work and routine communication.

The original rf board, fitted by Yaesu, suffers from several deficiencies. The chief of these are a distinct deafness (noise figures of 8 -10dB are not unusual in unmodified transceivers!) and a considerable susceptibility to strong-signal overload problems. Fitting a preamplifier can help with the first problem but at the expense of dynamic range. Of course, strong signal problems are not always recognised as such, but with the present level of 144MHz activity there can be few operators who are able to completely disregard signal handling problems. Of course there will always be those people (including some manufacturers') who will remain convinced that a little extra low noise pre-amplification can only do good.

The Mutek rf board has been designed to eliminate the need for preamplifiers while vastly improving the dynamic range of the system. To overcome the design problems presented, it has required careful attention to the linearity of the mixer and amplifiers with particular care being given to proper gain distribution.

Circuit Description

The rf stage is a very low noise ion-implanted dual-gate mosfet (3SK88/BF981/BF988) This device is capable of a genuine (device) noise figure of around 1dB. We have chosen to trade noise figure (nf) with dynamic range resulting in a system nf of perhaps 2dB or a little less. This is more than adequate for normal terrestrial operation and is probably quite acceptable for eme in most circumstances.

The rf stage feeds a three-pole bandpass filter: this has been designed to provide a 2 MHz bandwidth centred on 145 MHz (4 MHz centred on 146 MHz) with excellent stop-band performance. The filter is terminated with a resistive pad. This not only ensures that the filter is adequately terminated but also provides a very important broad-band termination for the input port of the ring mixer.

A ring mixer was chosen in preference to the more usual fet for two reasons: the most obvious is that it is much easier to achieve adequate dynamic range with the ring. A second, possibly more subtle reason, is that the inherently balanced structure of the ring results in cancellation of local oscillator am noise. As the phase locked translation loop local oscillator (lo) in the 221 and 225 series generates quite large am noise sidebands, a balanced mixer is mandatory.

Proper termination of the mixer is essential for reproducible high performance operation. The local oscillator (lo) is terminated with a 5dB pad: this ensures a good broadband match. There is enough power available at the output of the class A lo buffer to ensure proper mixer performance. The mixer port which requires most careful termination is the if output. The network here has several functions: it must transform the 50Ω output impedance of the diode ring to the optimum source impedance required by the mosfet post-amplifier; it must ensure that the mixer has a dc earth return and, most importantly, it must provide a satisfactory termination for the vhf and uhf products

generated in the mixing process. The 10.7MHz impedance transformation is accomplished with an L-network, while the rf choke provides the earth return. The series RC network on the mixer output provides a monotonically increasing return-loss with frequency, thus ensuring proper termination of the vhf and uhf mixing products.

The mixer post-amplifier is a low noise mosfet which is operated at a high drain current for good intermodulation performance. Although some degradation of the noise figure can be seen, it is still very low and has a minimal effect upon the mixer noise figure. The device also provides the correct source impedance for the following 6-pole crystal filter.

After the crystal filter the linearity requirements become less severe but the same circuit techniques are employed. Dual-gate mosfets are used for both the fm and ssb if head amplifiers. The output of the ssb amplifier drives the noise-blanker gate. The agc is applied slightly differently between the FT221/225GT and RPBC144ub boards - see circuit diagrams.

The circuit is constructed on a very high quality plated through hole pcb (NOTE: depends on age of pcb.).

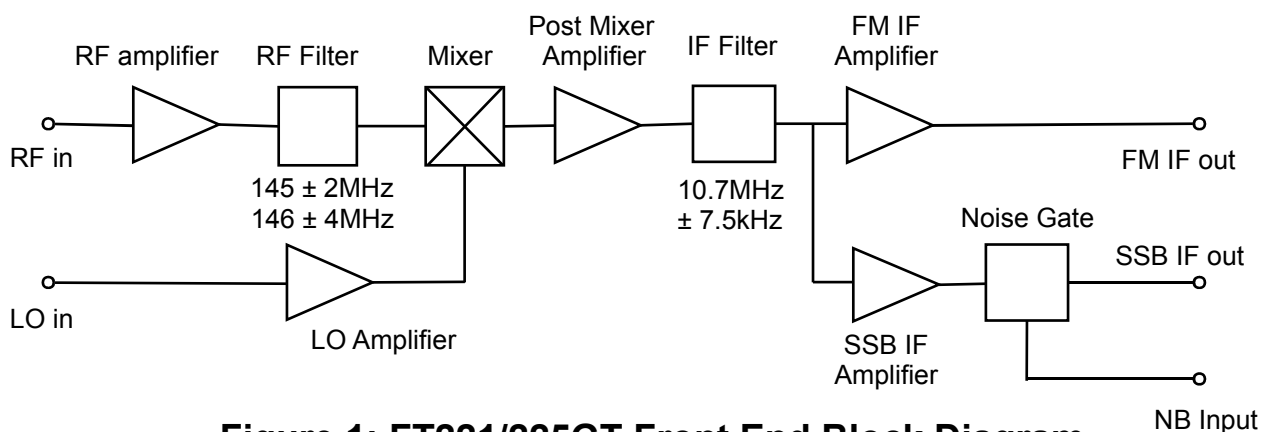

Figure 1: FT221/225GT Front End Block Diagram

Installation Notes

There are two small internal modifications that are required in order to make the Mutek rf board compatible with the unmodified FT221/225. They are both reversible.

The first provides a switched 13.5V line to power the new rf board on receive only. The original board operates from an 8V rail which potentially limits dynamic range.

The second is to switch the 8V supply to the noise blanker if strip. The noise blanker gate doubles as a diode switch for the ssb filter t-r switching. To improve the blanker action we have re-dimensioned the blanker gate biasing. A result of this is that diode switch needs to be solidly reverse biased in order to avoid losses in the ssb transmit mode.

The modifications described below apply to both the FT221 and FT225. We strongly suggest that the voltage checks detailed are made to confirm the function of the relevant pins. If you have any queries please don't hesitate to contact us.

Detailed Installation

First of all - UNPLUG THE TRANSCEIVER FROM THE MAINS

1. Remove both the top (4 clips) and bottom (12 screws) covers from the transceiver. Unplug the loudspeaker connection.
2. Remove the original rf board.
3. Remove the metal carrier from the original rf board.
4. Fix the carrier to the Mutek board, taking care to ensure that the orientation is the same as the original.
5. Turn the transceiver over to expose the underside of the unit.
6. *Locate Pin 18 (or B9) on the ssb if unit edge connector J20. (This has 13.5V on receive: 0V on transmit.)
7. Locate Pin 3 on the rf unit edge connector J15.
8. If pin 3 has a lead connected to it, remove the lead and insulate the free end.
9. *Run the longer of the two leads supplied between Pin 18 (or B9) of the ssb if unit edge connector to Pin 3 of the rf unit edge connector
10. Locate Pin 13 on the fm if unit edge connector J19 (this will have 8v on it).
11. Remove the leads soldered to this pin (if there is a decoupling capacitor soldered to the pin don't remove it.) Insulate the bare ends of the leads (which should be soldered together).
12. *Locate Pin 9 (or A5) on the ssb if unit edge connector (this has 8V on receive: 0v on transmit).
13. *Run the shorter of the leads supplied with the new board between Pin 13 of the fm if unit edge connector and Pin 9 (or A5) of the ssb if unit edge connector.
14. Turn the transceiver up the right way.
15. Plug in the Mutek rf board (the 'track' side of the board faces the front).
16. Check the receiver performance on an antenna.
17. Refit the bottom and top covers - don't forget to plug in the loudspeaker.
18. Now get in amongst the dx!

*NOTE: The double sided edge connectors are labelled A1 to A9 and B1 to B9 but the pcbs are labelled pins 1 to 18. A1 is pin 1, B1 is pin 2, A2 is pin 3, B2 is pin 4 etc.

Pin 1	gnd	Pin 7	mkr/nc	Pin 13	nc
Pin 2	agc	Pin 8	gnd	Pin 4	ssb if
Pin 3	+13.5 V	Pin 9	fm if	Pin 15	blanker
Pin 4	gnd	Pin 10	gnd	Pin 16	gnd
Pin 5	antenna	Pin 11	nc	Pin 17	lo
Pin 6	mkr/nc	Pin 12	gnd	Pin 618	end

Table 1: Edge Connector Pin Allocations

Additional Notes

1. It may well be necessary to reset the S meter zero and full-scale adjustments. (Mode switch to AM. With RF gain fully CCW, adjust VR902 on PB1462 until S-meter indicates 10. Then with RF gain fully CW adjust VR903 on PB1462 until S-meter reads zero. Repeat procedure until tracking is complete.)
2. The addition of a relatively narrow band crystal filter prior to the noise amplifier inevitably causes some deterioration of the noise blanker performance. The new biasing of the noise blanker gate minimises this effect. Some reduction in performance can be expected, particularly with low level pulses. It has also been observed that when the original rf board is used with a preamplifier, the dynamic range has been so small that the rf board has been operating as a saturating rf noise limiter.
3. In circumstances where the lowest possible noise figure is required, the transceiver's internal change-over circuit losses may be unacceptable. In order to bypass the antenna relay, a link is provided (INPUT LINK) on the Mutek board in put micro-stripline which may be broken to allow a direct connection to be made to the rf stage gate circuit.

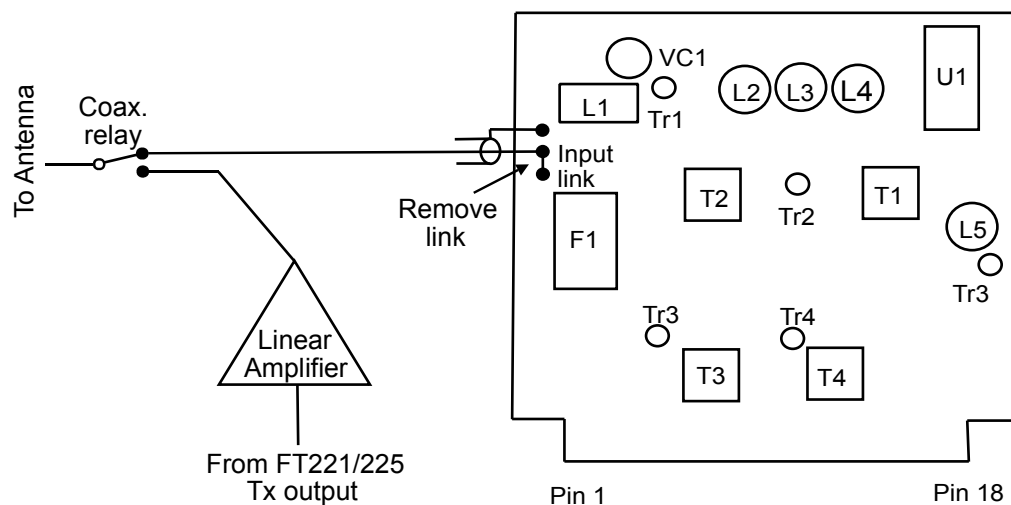

Figure 2: Minimum Noise Figure Modification

Data for FT221/225GT

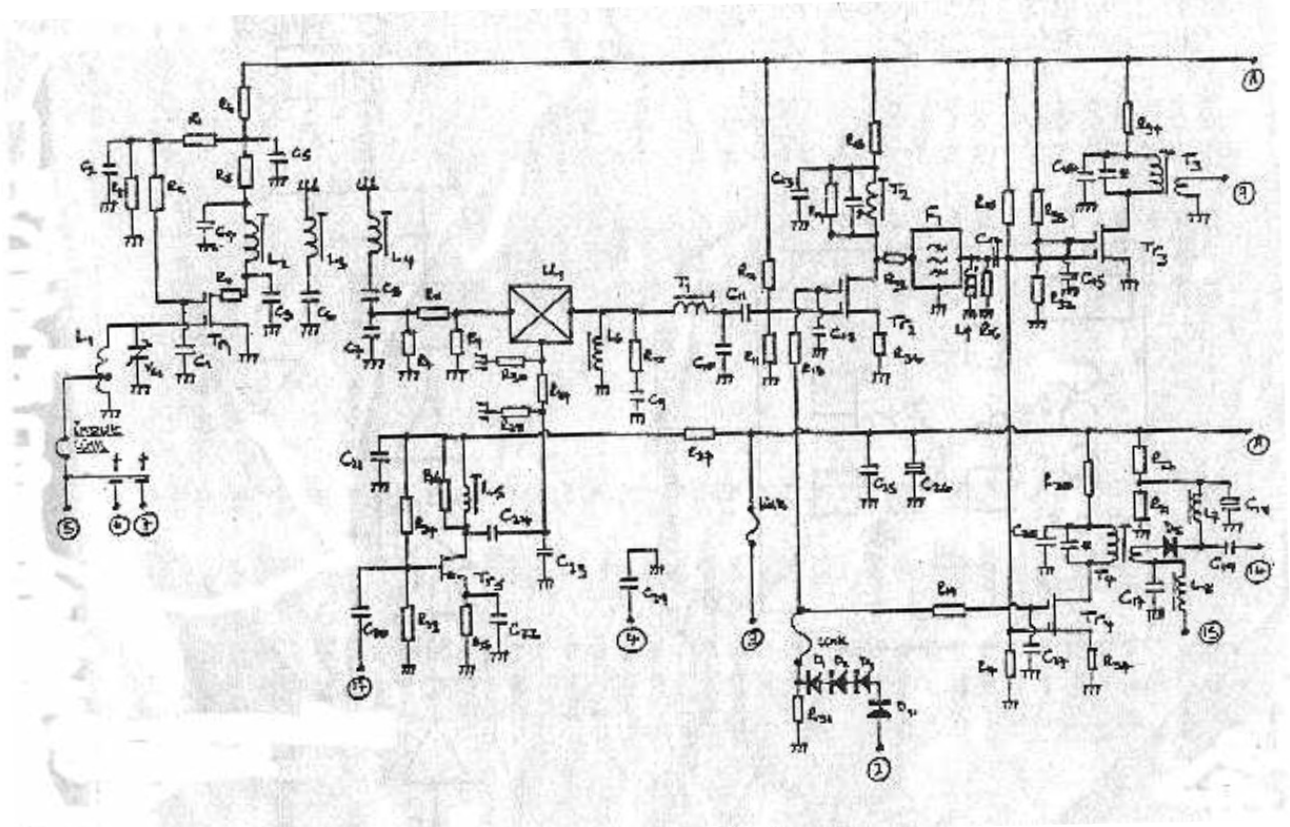

Figure 3: FT221/225GT Circuit Diagram

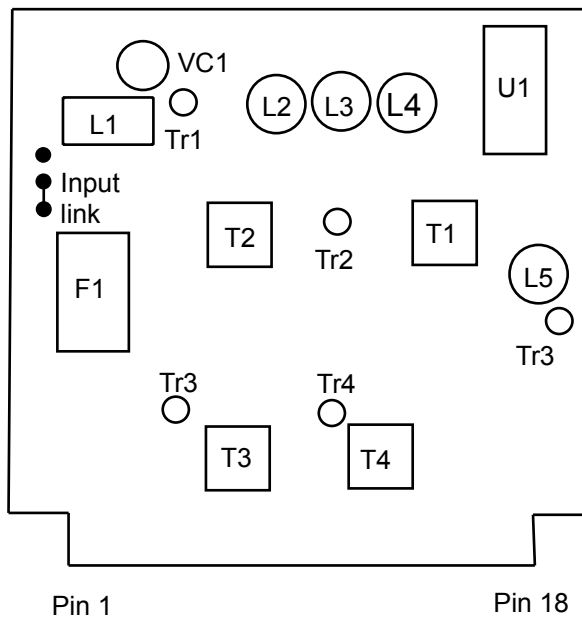

Figure 4: FT221/225GT Component Layout

Table 2: FT221/225GT Component Listing

R1	39k	R31	100R	C23	10n
R2	82k	R32	100R	C24	2u2
R3	150R	R33	100R	C25	1n0
R4	470R	R34	10k	C26*	Not fitted
R5	11R	R35	39k	C27	10n
R6	470R	R36	100R	C28	1n0
R7	150R	R37	100R	C29	1n0
R8	180R	R38	10R	C30	10n
R9	180R	C1	2/10p variable	C31	2u2
R10	27R	C2	1n0	L1	Tapped coil
R11	10k	C3	8p2	L2	Toko S18, Al slug
R12	4k7	C4	1n0	L3	Toko S18, Al slug
R13	33k	C5	12p	L4	Toko S18, Al slug
R14	51R	C6	1n0	L5	Toko S18, Al slug
R15	330k	C7	100p	L6	TKACS 4520
R16	39k	C8	12p	L7	TKACS 4520
R17	39R	C9	47p	L8	220uH
R18	39k	C10	10p	L9	2uH
R19	82k	C11	1n0	L10	TKACS 4520
R20	1k5	C12	1n0	L11	15uH
R21	10R	C13	1n0	L12	47uH
R22	1k5	C14	68p	L13	TKACS 4520
R23	3k3	C15	100p	XF1	10M15D1
R24	82k	C16	1n0	X1	SBL-1
R25	100R	C17	10n	D1*	MPN3404, 1N4148
R26	1M0	C18*	Not fitted	D2-5	1N4148
R27	39k	C19	10n	TR1*	BF981, BF988
R28	39k	C20	1n0	TR2	BF199
R29	5k6	C21	10n	TR3-5*	BF981, BF988
R30	3k9	C22	10n		

*NOTE: There appears to have been some change in component choice during production of this unit. This has not been fully documented.

Data for RPBC144ub

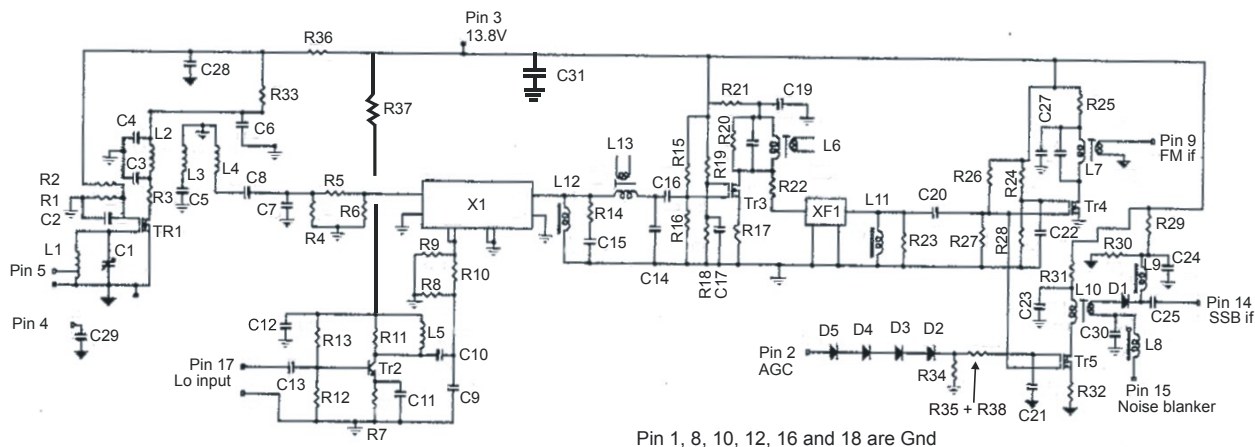

Note 1: There is a link on the muTek rf board between pin 5 and the tap on L1.
 Note 2: R38 is 10R and acts only as a link across a pcb track.

Note 3: Capacitor shown across L6 and L7 are designated C18 and C26 but are not fitted.
 Note 4: There maybe an additional resistor (47R SMD) fitted on the back of the pcb in series with gate 2 of TR3. See Change Note #003.

Figure 5: RPBC144ub Circuit Diagram

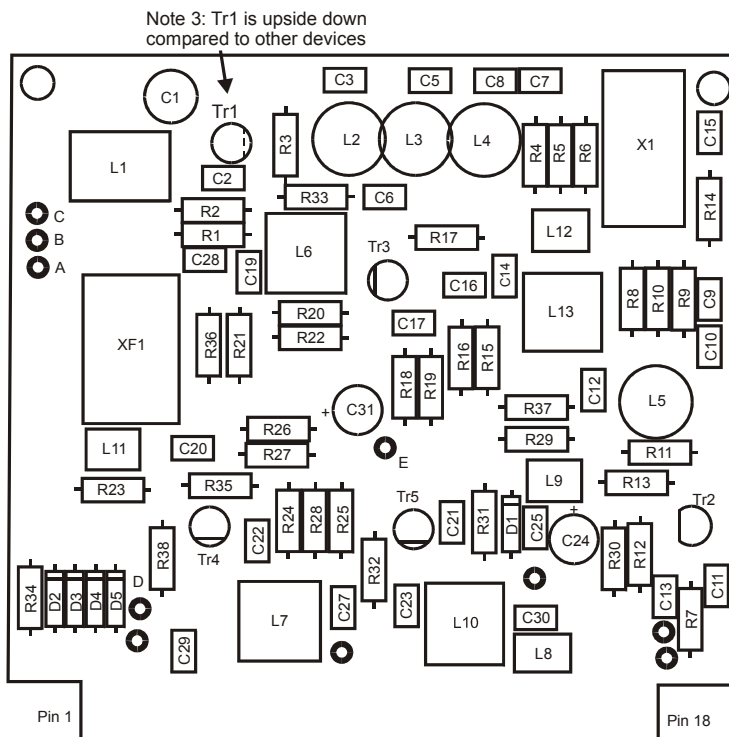

Note 1: There is normally a link from A to B and from D to E on the pcb.
 Note 2: There may be an additional resistor (47R SMD) on the track side. See Change Note #003.

Figure 6: RPBC144ub Component Layout

Table 3: RPBC144ub Component Listing

R1	39k	R31	100R	C23	10n
R2	82k	R32	100R	C24	2u2
R3	150R	R33	100R	C25	1n0
R4	470R	R34	10k	C26*	Not fitted
R5	11R	R35	39k	C27	10n
R6	470R	R36	100R	C28	1n0
R7	150R	R37	100R	C29	1n0
R8	180R	R38	10R	C30	10n
R9	180R	C1	2/10p variable	C31	2u2
R10	27R	C2	1n0	L1	Tapped coil
R11	10k	C3	8p2	L2	Toko S18, Al slug
R12	4k7	C4	1n0	L3	Toko S18, Al slug
R13	33k	C5	12p	L4	Toko S18, Al slug
R14	51R	C6	1n0	L5	Toko S18, Al slug
R15	330k	C7	100p	L6	TKACS 4520
R16	39k	C8	12p	L7	TKACS 4520
R17	39R	C9	47p	L8	220uH
R18	39k	C10	10p	L9	2uH
R19	82k	C11	1n0	L10	TKACS 4520
R20	1k5	C12	1n0	L11	15uH
R21	10R	C13	1n0	L12	47uH
R22	1k5	C14	68p	L13	TKACS 4520
R23	3k3	C15	100p	XF1	10M15D1
R24	82k	C16	1n0	X1	SBL-1
R25	100R	C17	10n	D1*	MPN3404, 1N4148
R26	1M0	C18*	Not fitted	D2-5	1N4148
R27	39k	C19	10n	TR1*	BF981, BF988
R28	39k	C20	1n0	TR2	BF199
R29	5k6	C21	10n	TR3-5*	BF981, BF988
R30	3k9	C22	10n		

*NOTE: There appears to have been some change in component choice during production of this unit. This has not been fully documented.

Copy of Change Note: #003

Issue: 1

Date:09/12/91

Affects: RPBC144ub

Procedure: New Production and Update Repair PCBs

Reasons: UHF instability of first 10.7Mhz stage.

Action: Add 47R SM resistor in series with TR3 gate 2
Mark A near wording Issue 1 on track side

